

NEMESIS 9003B/HBT™



NEMESIS 9003B/HBT™ Heavy duty Brinell hardness testers



General information

NEMESIS 9003B/HBT, represents the latest top of the range development of high speed production Brinell hardness testing. Modern design, innovated technology, based on the application of precision mechatronic components. A superior level of precision combined with advance graphic images for maximum test procedure control.

The NEMESIS 9003B/HBT represents Brinell hardness testing at the highest possible standard. Aircraft engine parts, automobile parts, production lines, general quality assurance and laboratory use, are all fields covered by the NEMESIS 9003B/HBT.

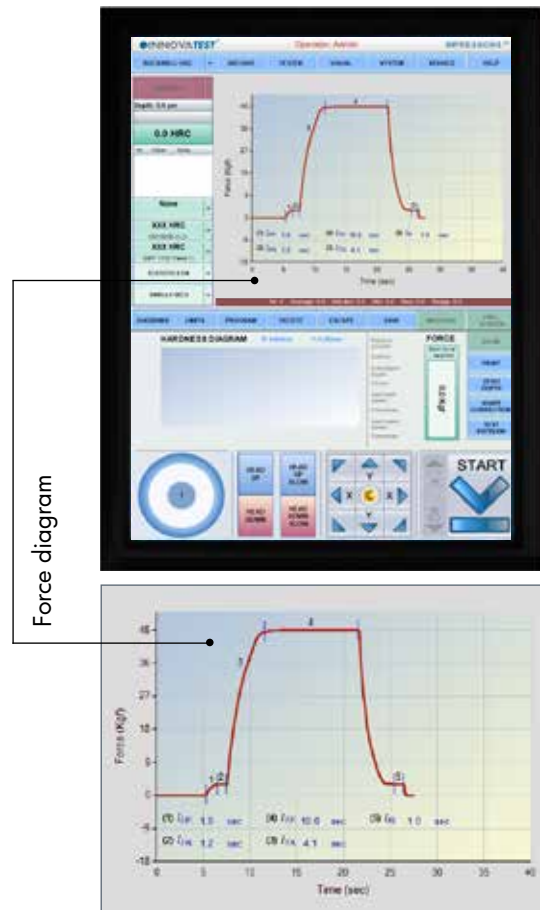

Features

- Meets or exceeds, ISO, ASTM, JIS standards
- Brinell and Brinell depth measurement (HBT)
- Superior range of testloads/force application ranging from 5kgf/49N to 3000kgf/29kN
- Fixed workpiece position (no spindle)
- Descending test head with automatic workpiece detection
- Extended indenter base with high force clamping attachment and indenter protection
- PC based INNOVATEST IMPRESSIONS™ hardness testing firmware and database file system, standard
- Large, adjustable 15" industrial touch screen
- Built-in industrial SSD hard drives offer nearly endless file storing
- LAN, WLAN, USB-2, RS-232, Printer and DVI connectivity
- Optional: On board built-in driver for motorized Y-stage (Jominy testing) or X-Y stage (Pattern testing)
- Free definable test patterns case depth, traverse, free style, etc. (optional)
- Machine covers made of shock, damage and fire proof recyclable ABS
- Large range of optional accessories
- Large testpiece accommodation H=380mm, D=220mm

NEMESIS 9003B/HBT has a rigid linear force actuator to move the test head in the required position. This can be done in 2 different ways. The test head will decent to the workpiece after pressing the start button. The descending can also be realized in a manual high speed mode or slow movement mode.

Technical specifications

NEMESIS 9003B/HBT™	
Hardness scales 9003B	Brinell
Hardness scales 9003HBT	Brinell, Brinell depth (HBT)
Load application	Load cell, force feedback, closed loop system
Load range	5kgf/49N - 3000kgf/29kN
Optical system	Brinell microscope
Electronic system	High performance embedded micro PC, MS Windows, 15" full color touch screen, automatic and manual measurement
Standards	Meets or exceeds, ASTM-E10, ISO 6506
Test loads	5kgf/49N, 6.25kgf/62N, 10kgf/98N, 15.625kgf/153N, 20kgf/196N, 25kgf/245N, 30kgf/294.2N, 31.25kgf/306N, 50kgf/490N, 62.5kgf/612N, 100kgf/980.7N, 120kgf/1176N, 125kgf/1225N, 187.5kgf/1838N, 250kgf/2.45kN, 500kgf/4.9kN, 750kgf/7.35kN, 1000kgf/9.8kN, 1500kgf/14.7kN, 3000kgf/29kN
Brinell test range	HB1: 5kgf/49N, 10kgf/98N, 30kgf/294.2N HB2.5: 6.25kgf/62N, 15.625kgf/153N, 31.25kgf/306N, 62.5kgf/612N, 187.5kgf/1838N HB5: 25kgf/245N, 62.5kgf/612N, 125kgf/1225N, 250kgf/2.45kN HB10: 100kgf/980.7N, 250kgf/2.45kN, 500kgf/4.9kN, 750kgf/7.35kN, 1000kgf/9.8kN, 1500kgf/14.7kN, 3000kgf/29kN HBT: 5kgf/49N, 250kgf/2.45kN Depending on model
Test cycles	Fully automatic, automatic and manual
Force tolerance	<0.5%
Force control	1 - 99 seconds
Connectivity	USB (4), UTP-RJ45-LAN, W-LAN, RS232, Motorized X-Y stage
Tester color (standard)	Black/Metallic silver
Vertical displacement	300mm
Workpiece accommodation	Vertical capacity 380mm, Horizontal capacity 220mm (from center-line)
Operating temperature	10°C to 35°C, non-condensing
Machine dimensions	400mm x 650mm x 1440mm (WxDxH)
Machine weight	190kg
Power supply	100V AC to 240V AC, 50Hz/60Hz, single phase

Standard delivery

- Testing table, hardened, \varnothing 200mm
- Brinell microscope
- Wireless mouse and keyboard
- Power cable
- Four adjustable feet
- INNOVATEST® calibration certificate
- Installation and user manual

Optional accessories

- Certified indentors (ASTM, DIN, ISO)
- Certified reference hardness blocks (ASTM, DIN, ISO)
- V-anvil, hardened, \varnothing 80mm
- Large testing table, 350mm x 250mm, with T-grooves
- Extra large testing table, cylinder head 450mm x 350mm, with grooves and support
- Cylinder head/blok test table, 650mm x 400mm
- Motorized X-Y stages, motorized rotary or tilting tables
- Built-in 5 axis support driver
- Brinell optical scanning system
- Solid tester table and storage cabinet



NEMESIS 9003B/HBT equipped with (standard) testing table \varnothing 200mm.



The NEMESIS 9003B/HBT can be equipped with manual and motorized X-Y stages. Above picture shows optional 250Kgf motorized X-Y stage



The optional 450mm x 350mm large testing table with T-slots can be used for large and heavy workpieces.

Order details

NEMESIS 9003B

Brinell hardness tester
test forces 5kgf/49N until 3000kgf/29kN

NEMESIS 9003HBT

Brinell hardness tester with depth measurement HBT,
test forces 5kgf/49N until 3000kgf/29kN

NEMESIS 9003B/HBT™

Heavy duty Brinell hardness testers

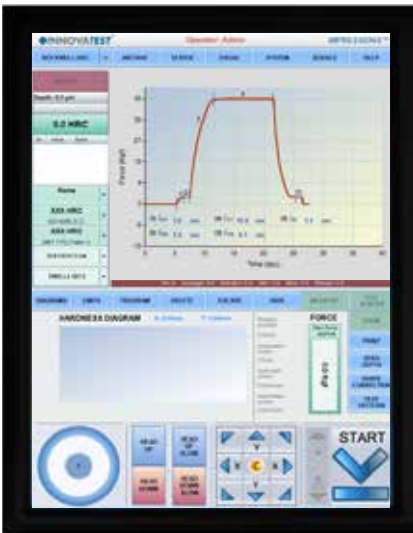

The screenshot shows a detailed report from the INNOVATEST software. At the top, it says 'INNOVATEST'. Below that, there are fields for 'Tester Info' and 'Hardware'. The 'Tester Info' section includes: Type: NEMESIS, Model: 4.1.0002, Operation: Admin, Test: 0000011001001, and Specimen: 10 mm. The 'Hardware' section includes: No. of Measurement: 0, Max: 1000.00, Min: 1000.00, Package: 1000.00, and Standard Deviation: 0.17. Below this, there is a 'CASE DEPTH DIAGRAM' table with columns for 'CASE DEPTH (mm)' and 'FORCE (kgf)'. The table has several rows of data. At the bottom, there are buttons for 'Print', 'Save', and 'Close'.

NEMESIS 9003B/HBT has an advanced report generator allowing you to print sophisticated customized result reports and statistics.

NEMESIS 9003B/HBT can be equipped with an automatic motorized spindle (optional) which makes it possible to position your workpiece without any effort.

IMPRESSIONS™ hardness testing firmware and workflow control.



Technical drawing NEMESIS 9003B/HBT™

All dimensions are in mm

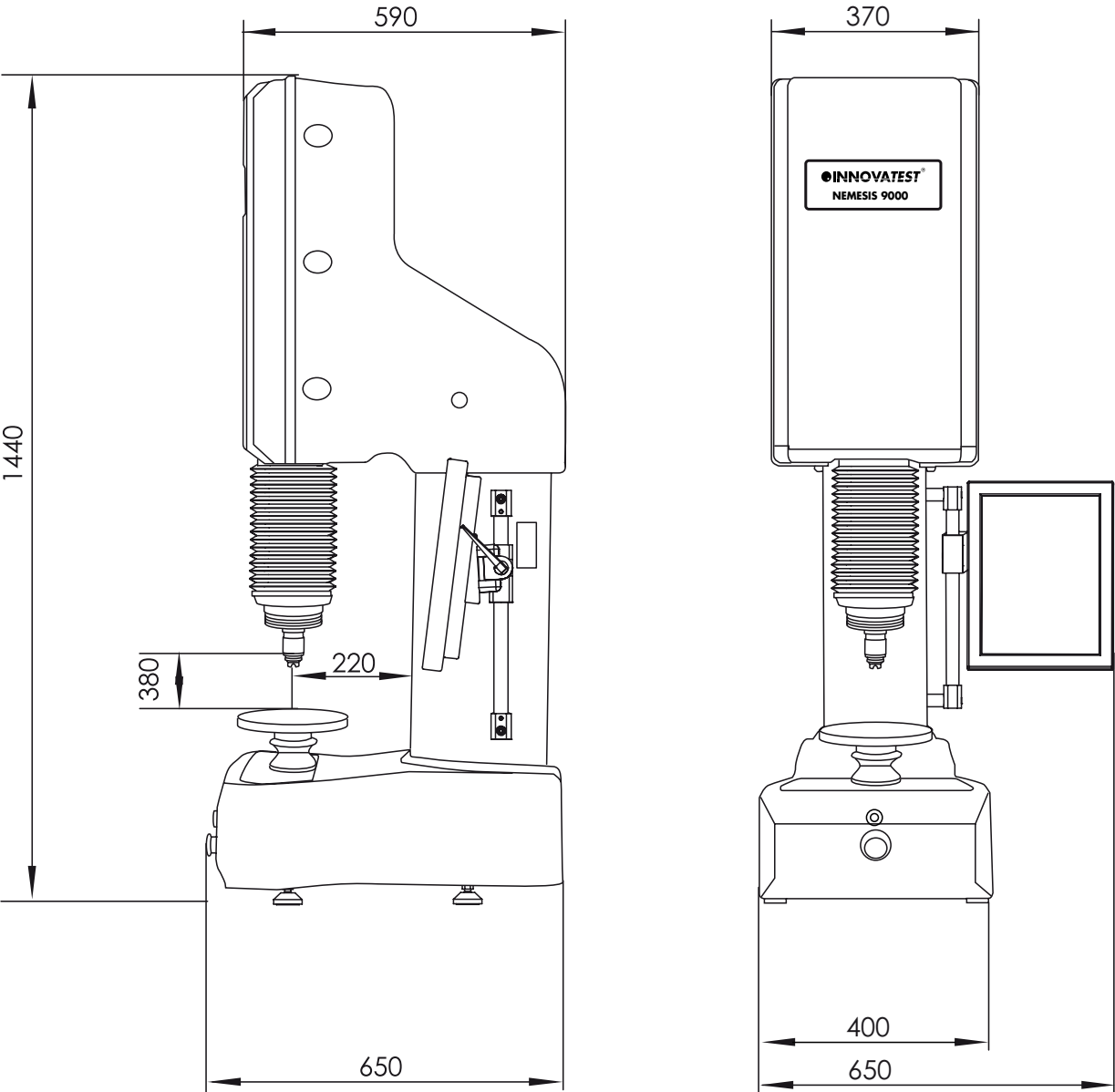

Kapcsolat, bővebb információ:



Sidex Trade Kft.

1224 Budapest, Dózsa György út 105.
TT Ipartelep (volt Mechanikai Művek)
Tel : (+36-1) 424-1705, Mobil: (+36-30) 9349-611
Fax :(+36-1) 424-1704
Web: <http://www.sidex.hu> – E-mail: info@sidex.hu

CORPORATE HEAD OFFICE

INNOVATEST Europe BV
mANuFACTuRING, DISTRIBuTION & SERVICE
Borgharenweg 140
6222 AA Maastricht (The Netherlands)
Phone: +31 43 3520060
Fax: +31 43 3631168
E-mail: info@innovatest-europe.com
Website: www.innovatest-europe.com

BRANCHE OFFICES

INNOVATEST Benelux BVBA
SAIES & SERVICE
Phone: +32 12 779002
Fax: +32 12 779003
E-mail: info@innovatest-benelux.com
Website: www.innovatest-europe.com

INNOVATEST Shanghai Co., Ltd.
ASIA & CHINA SAIES & SERVICE
Building 2, No.123, 1165 Nong Jindu Road,
South Metropolis Industrial Park
Minhang District, Shanghai, P.R. China
Zip code: 201108
E-mail: info@innovatest-shanghai.com
Website: www.innovatest-shanghai.com

Changes in products and/or product specifications can emerge due to new technologies and continuous development.

We reserve the right to change or modify specifications of products without prior notice.

We recommend you to contact our sales office for up-to-date information.

© All rights reserved